

The content of this specification may change without notification 9/23/2010

Custom solutions are available.

HOW TO ORDER

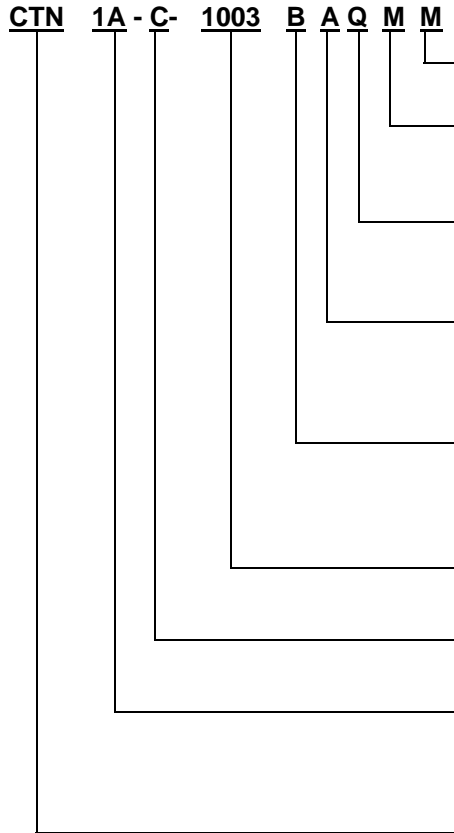

- Packaging**
M = Tape/Reel B = Bulk
- Tracking TCR**
L = 1 N = 3 Q = 10
M = 2 P = 5
- Absolute TCR**
P = ±5 X = ±25
Q = ±10
- Ratio Tolerance**
T = 0.01 B = 0.1
Q = 0.02 C = 0.25
A = 0.05 D = 0.5
- Absolute Tolerance (%)**
A = ±0.05 D = ±0.5
B = ±0.1 F = ±1
C = ±0.25
- Resistance Value**
3 sig. fig & 1 multiplier ±1%
- Circuit Layout**
Refer to Specification
- Model (Refer to Spec)**
1A 6D S8D
1D S6D M16D
2D 8D 16D
- Series**
High Precision Resistor Array & Networks



U-Shaped Product with Electrode Structure
Processed product with grooves

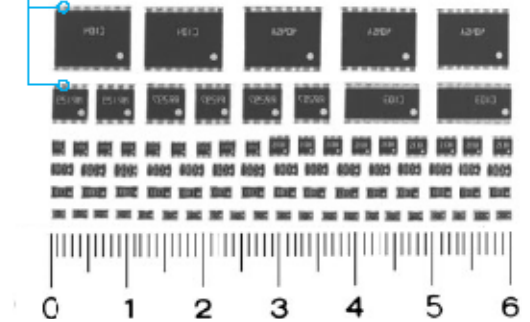

FEATURES

- AAC thin film network resistors ensure stable high performance as indicated by the excellent ratio T.C.R as between elements 1pp/°C or less and absolute T.C.R as 5 pp/°C. The absolute tolerance as 0.5%.
- "U-type" electrodes offering excellent durability, ensuring superb durability for soldering flow, re-flow soldering, or dip soldering, and is also very beneficial for the durability of wire bonding
 - A perfect solution to replace the network resistor of SOP, SIP or DIP types.
 - Lead Free and RoHs Compliant
 - Custom designed circuits are available upon special request

ELECTRICAL CHARACTERISTICS

Model	Total Rated Power	Resistance Range (Ω) by Circuit Configuration		
		B	2B	C
CTN1A	0.125 W	10 ~ 50K		10.0 ~ 100K
CTN1D	0.125 W	10 ~ 50K		10.0 ~ 100K
CTN2D	0.100 W	10 ~ 25K		10.0 ~ 50.0K
CTN6D	0.250 W		10.0 ~ 100K	10.0 ~ 100K
CTNS6D	0.150 W		10.0 ~ 10.0K	10.0 ~ 50.0K
CTN8D	0.500 W			10.0 ~ 200K
CTN8U	0.500 W			(1.00M ~ Total)
CTNS8D	0.125 W			10.0 ~ 50.0K
CTNM16D	1.00 W			2.00M Total
CTNM16U	1.00 W			2.00M Total
CTN16D	1.50 W			10.0M Total
CTN16U	1.50 W			10.0M Total

APPLICATIONS

- Medical Instrument
- Test Equipment For Semiconductor
- Precision Measuring Equipment
- Electric Components For Automotive

CONSTRUCTION

1. Epoxy Protective Film
2. Ni-Cr Resistive Element
3. Cu Electrode
4. Ni Plating and Tin Plating
5. High Purity Alumina Substrate

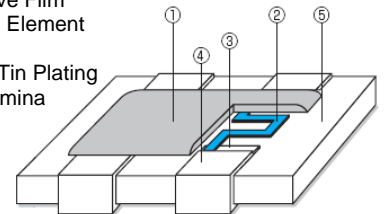

CIRCUIT LAYOUT

CTN1A, CTN1D, CTN2D		CTNS6D, CTN6D		CTNS8D, CTN8D, CTN8U	CTNM16D, CTNM16U, CTN16D, CTN16U
B	C	2B	C	C	C

DIMENSIONS (mm)

Model	L	W	P	a	b	c	d	e	f	g	t
CTN1A	3.2 ± 0.2	1.6 ± 0.2	2.0 ± 0.1	1.0 ± 0.1	1.0 ± 0.1	0.15 ± 0.05					0.55 max
CTN1D							0.4 ± 0.1				
CTN2D	2.0 ± 0.2	1.25 ± 0.2	1.3 ± 0.2	0.7 ± 0.2	0.6 ± 0.2	0.1 ± 0.05	0.25 ± 0.1				0.55 max
CTN6D	2.54 ± 0.1	2.54 ± 0.1	0.86 ± 0.1	0.43 ± 0.1	0.43 ± 0.2	0.41 ± 0.2	0.5 ± 0.2	0.41 ± 0.1			0.55 max
CTNS6D	2.0 ± 0.1	2.0 ± 0.1	0.72 ± 0.1	0.36 ± 0.1	0.36 ± 0.1	0.28 ± 0.2	0.4 ± 0.2	0.28 ± 0.1			0.55 max
CTN8D	5.08 ± 0.2	5.1 ± 0.2	1.27 ± 0.2	0.635 ± 0.1	0.635 ± 0.1	0.6 ± 0.2	0.8 ± 0.2	0.635 ± 0.1			0.9 max
CTN8U									0.2	0.1	
CTNS8D	3.2 ± 0.2	1.6 ± 0.2	0.8 ± 0.1	0.4 ± 0.1	0.4 ± 0.1	0.3 ± 0.2	0.4 ± 0.2	0.3 ± 0.1			0.55 max
CTNM16D	10.16 ± 0.2	5.1 ± 0.2	1.27 ± 0.2	0.635 ± 0.1	0.635 ± 0.1	0.6 ± 0.2	0.8 ± 0.2	0.635 ± 0.1			0.9 max
CTNM16U									0.2	0.1	
CTN16D											
CTN16U		0.2							0.1		

SCHEMATIC

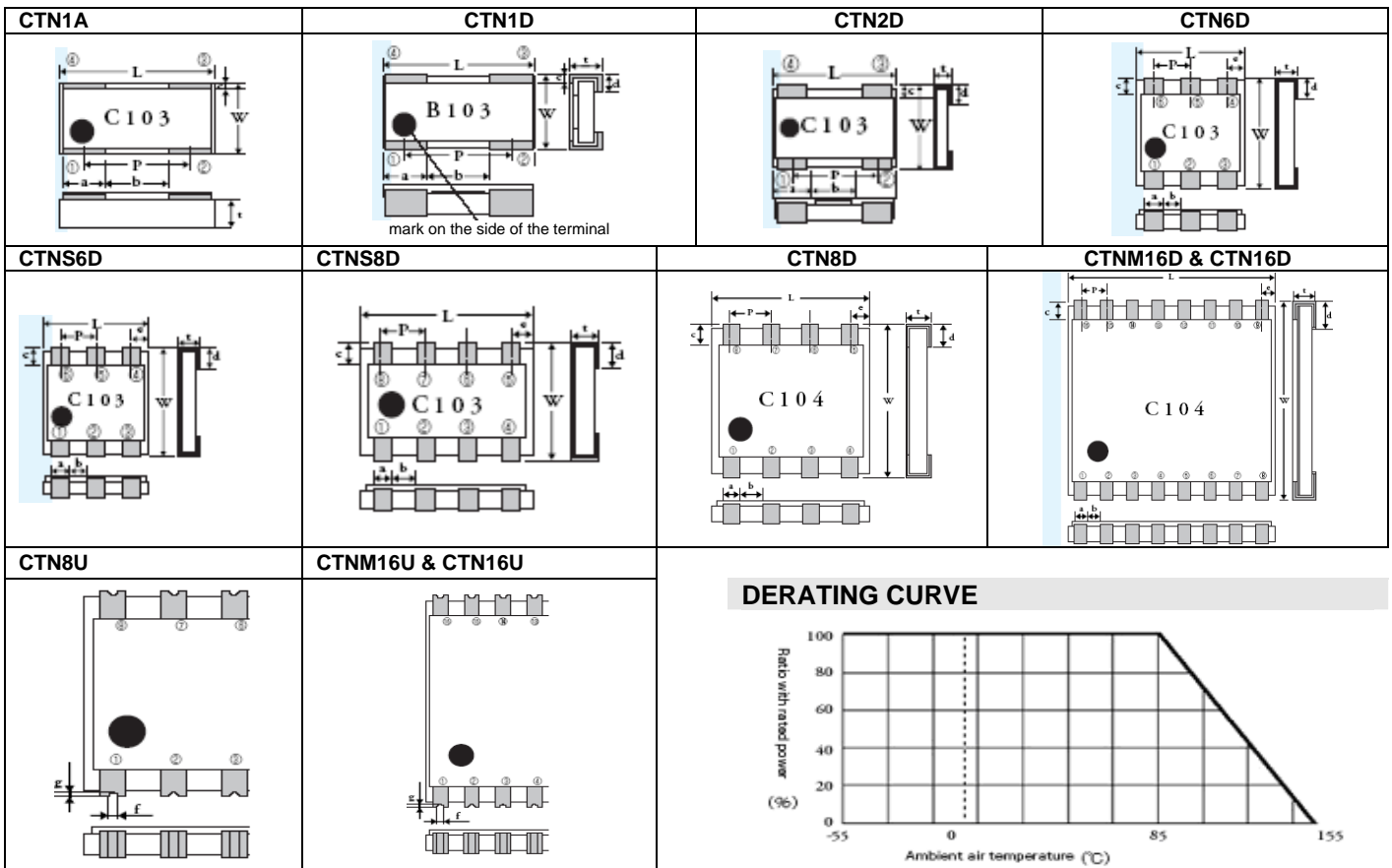

DERATING CURVE

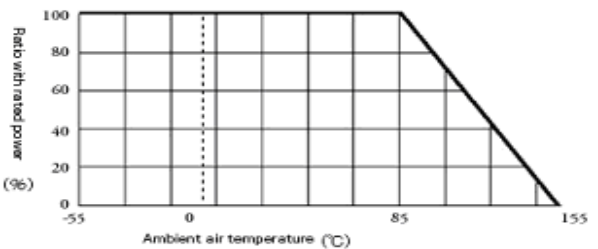

PERFORMANCE

Item	Test Condition	Specification
Short Time Overload	Application of 2.5 times the rated voltage for 5 seconds	± (0.1% + 0.05Ω)
Heat Resistance During Soldering	Dip in Solder at 260°C ± 5°C for 10 ± 1 seconds	± (0.05% + 0.05Ω)
Temperature Cycles	100 cycles between -55°C ~ +125°C	± (0.1% + 0.05Ω)
Service Life Under Heavy Load	1,000 hours at 85°C, rated voltage with intermittent load	± (0.1% + 0.05Ω)
Longevity Under Heavy Humidity Load	95% RH for 1000 hrs at 40°C, rated voltage with intermittent load	± (0.1% + 0.05Ω)
Absolute Value indicating Secular Change	1 year at ambient temperature, normal humidity without load	±50ppm (within ±50ppm / year)
Relative Value Indicating Secular Change	1 year at ambient temperature, normal humidity without load	±10ppm (within ±10ppm / year)