

The content of this specification may change without notification 06/08/07

CTL05/CTL16/CTL10/CTL18/CTL12/CTL01 Series Chip Resistor

Custom solutions are available.

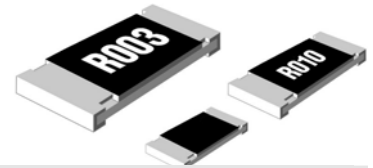

HOW TO ORDER

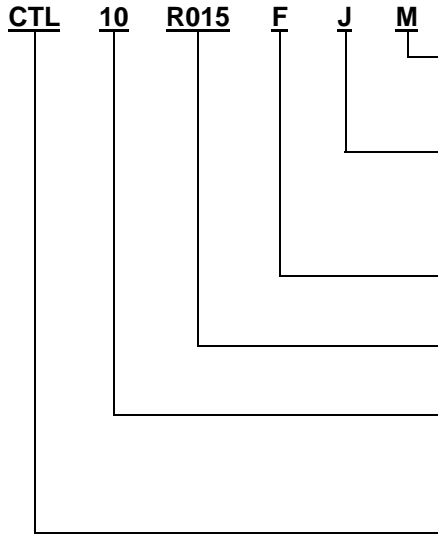

Packaging

M = 7" Reel (10" Reel for 2512)
V = 13" Reel

TCR (ppm/°C)

R = ±15 X = ±25 Y = ±50
J = ±75 K = ±100 L = ±200
N = ±350 P = ±500

Tolerance (%)

F = ± 1.0 G = ± 2.0 J = ± 5.0

EIA Resistance Code

Three significant digits and # of zeros

Size

05 = 0402 10 = 0805 12 = 2010
16 = 0603 18 = 1206 01 = 2512

Series

Precision Current Sense Resistor

FEATURES

- Resistance as low as 0.001 ohms
- Ultra Precision type with high reliability, stability and quality
- RoHS Compliant
- Extremely Low TCR, as low as ± 75 ppm
- Wrap Around Terminal for Flow Soldering
- Anti-Leaching Nickel Barrier Terminations
- ISO 9002 Quality Certified
- Applicable Specifications: EIA575, IEC 60115-1, JISC5201-1, CECC 40401, MIL-R-55342D

SCHEMATIC

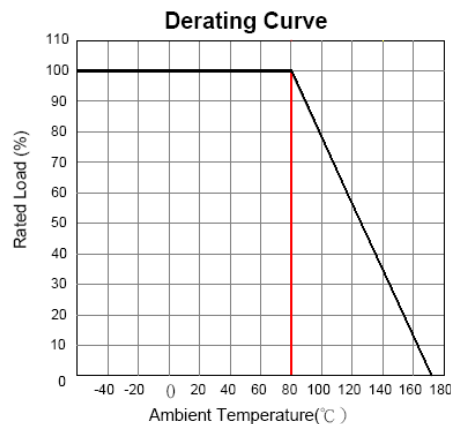
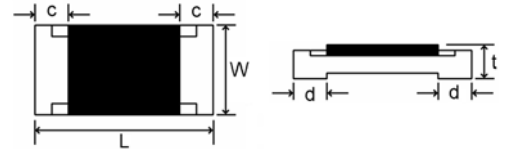

DIMENSIONS (mm)

Series	Size	L	W	c	t
CTL05	0402	1.00 ± 0.10	0.50 ± 0.10	0.20 ± 0.10	0.35 ± 0.10
CTL16	0603	1.60 ± 0.10	0.80 ± 0.10	0.20 ± 0.10	0.45 ± 0.10
CTL10	0805	2.00 ± 0.20	1.25 ± 0.20	0.60 ± 0.15	0.50 ± 0.15
CTL18	1206	3.20 ± 0.20	1.60 ± 0.15	1.00 ± 0.15	0.50 ± 0.15
CTL12	2010	5.00 ± 0.20	2.50 ± 0.20	1.70 ± 0.15	0.50 ± 0.15
CTL01	2512	6.40 ± 0.20	3.20 ± 0.20	2.00 ± 0.15	0.50 ± 0.15

ELECTRICAL CHARACTERISTICS

Size	Rated Power	Tol	Max TCR (ppm/°C)					Max Working Voltage	Max Overload Voltage
			±75ppm	±100ppm	±200ppm	±350ppm	±500ppm		
0402	.125W	2%			0.100 ~ 4.70			25V	50V
		5%			0.100 ~ 4.70				
0603	.125W	1%			0.100 ~ 0.680			50V	100V
		2%			0.100 ~ 0.680				
		5%			0.100 ~ 0.680				
0805	.250W	1%	0.100 ~ 0.500		0.022 ~ 0.080	0.01 ~ 0.039		150V	300V
		2%			0.022 ~ 0.080	0.01 ~ 0.039			
		5%			0.022 ~ 0.080	0.022 ~ 0.068			
1206	.50W	.5%	0.100 ~ 0.500	0.068 ~ 0.470	0.033 ~ 0.047	0.018 ~ 0.027		200V	400V
		1%		0.056 ~ 0.470	0.033 ~ 0.047	0.027			
		2%		0.056 ~ 0.470	0.033 ~ 0.047	0.018 ~ 0.027	0.01 ~ 0.015		
2010	.75W	.5%						200V	400V
		1%	0.100 ~ 0.500	0.056 ~ 0.470	0.001 ~ 0.0649	0.027			
		2%		0.056 ~ 0.470	0.001 ~ 0.0649	0.018 ~ 0.027	0.01 ~ 0.015		
2512	1.0W	.5%		0.056 ~ 0.470	0.001 ~ 0.0649	0.018 ~ 0.027		200V	400V
		1%	0.100 ~ 0.500	0.056 ~ 0.470	0.001 ~ 0.0649	0.027			

The content of this specification may change without notification 06/08/07

	2%	0.056 ~ 0.470	0.001 ~ 0.0649	0.018 ~ 0.027	0.01 ~ 0.015		
--	----	---------------	----------------	---------------	--------------	--	--

NOTE: The temperature range is -55°C ~ +150°C

Rated Voltage = $\sqrt{P \cdot R}$

CTL05/CTL16/CTL10/CTL18/CTL12/CTL01 Series Chip Resistor

PERFORMANCE

Test Item	Maximum $\Delta \Omega$		Condition
	F	G, J	
Short Time Overload	$\pm 0.1\%$	$\pm 0.5\%$	2.5 times of the rated voltage shall be applied for 5 seconds
Load Life	$\pm 0.25\%$	$\pm 0.5\%$	The resistor shall be subjected to rated voltage for 90 min. followed by a pause of 30 min. at a temperature of 70 \pm 3°C. This constitutes 1 cycle. Cycles shall be repeated for 1000 hours.
Moisture Load Life	$\pm 0.25\%$	$\pm 0.5\%$	The resistor subjected to rated voltage for 90 min followed by a pause for 30 min at a temperature of 60 \pm 2°C with relative humidity of 90% to 95%. This constitutes 1 cycles. Cycles shall be repeated for 1000 hours.
Temperature Cycle	$\pm 0.1\%$	$\pm 0.5\%$	[-55°C 30 min \rightarrow +125°C 30 min \rightarrow R.T. 3 min] The resistor shall be subjected to 5 continuous cycles
Resistance to Solder Heat	$\pm 0.1\%$	$\pm 0.5\%$	The resistor shall withstand dipped into solder for 10 \pm 1 sec. At 260 \pm 5°C
Terminal Strength	$\pm 0.1\%$	$\pm 0.5\%$	Distance between fulcrums: 90mm; Bending width: 3 mm
Insulation Resistance	DC 500V for 1 min.		1000 Meg Ω or over
Solderability	A new uniform coating of solder shall cover minimum of 95% of surface being immersed The resistor shall be dipped into the solder of 215 \pm 5°C for 3 \pm 0.5 seconds		

PACKAGE QUANTITY

Package Type	CTL05	CTL16	CTL10	CTL18	CTL12	CTL01	CTL1S
M	10,000	5,000	5,000	5,000	5,000	5,000	2,000

TAPE SCHEMATIC

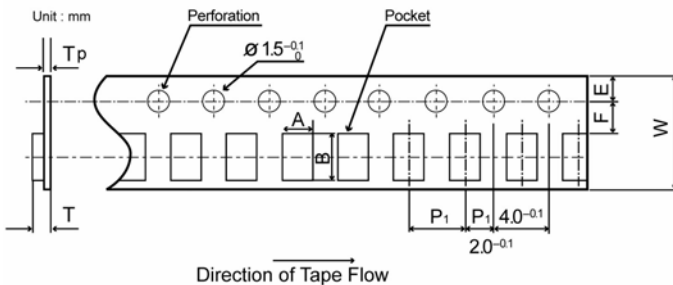

REEL SCHEMATIC

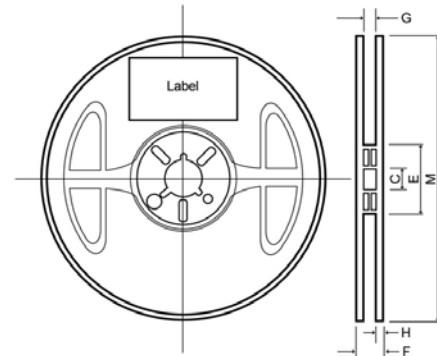

TAPE DIMENSIONS (mm)

	A	B	W	E	F	P ₁	T	T _p
CTL05	0.65 \pm 0.1	1.15 \pm 0.1	8.0 \pm 0.2	1.75 \pm 0.10	3.5 \pm 0.05	2.0 \pm 0.05	0.55 \pm 0.1	0.20 \pm 0.05
CTL16	1.1 \pm 0.2	1.9 \pm 0.2	8.0 \pm 0.2	1.75 \pm 0.1	3.5 \pm 0.05	4.0 \pm 0.1	0.70 \pm 0.1	0.20 \pm 0.05
CTL10	1.65 \pm 0.2	2.4 \pm 0.2	8.0 \pm 0.2	1.75 \pm 0.1	3.5 \pm 0.05	4.0 \pm 0.1	0.85 \pm 0.1	0.20 \pm 0.05
CTL18	2.0 \pm 0.15	3.6 \pm 0.15	8.0 \pm 0.2	1.75 \pm 0.1	3.5 \pm 0.05	4.0 \pm 0.1	0.85 \pm 0.1	0.20 \pm 0.05
CTL12	2.9 \pm 0.1	5.3 \pm 0.1	12.0 \pm 0.2	1.75 \pm 0.1	5.5 \pm 0.05	4.0 \pm 0.1	1.0 \pm 0.1	0.25 \pm 0.1
CTL01	3.4 \pm 0.1	6.6 \pm 0.1	12.0 \pm 0.2	1.75 \pm 0.1	5.5 \pm 0.05	4.0 \pm 0.1	1.0 \pm 0.1	0.25 \pm 0.1
CTL1S	3.4 \pm 0.1	6.6 \pm 0.1	12.0 \pm 0.2	1.75 \pm 0.1	5.5 \pm 0.05	4.0 \pm 0.1	1.0 \pm 0.1	0.25 \pm 0.1

REEL DIMENSIONS (mm)

Reel	M	H	C	G	E	F
7"	180 \pm 3.0	1.20	13.0 \pm 0.2	9.0 \pm 0.3	60 \pm 1.0	11.4 \pm 1.0
10"						
13"						

LABEL DESCRIPTION

One side surface of a reel is marked with a label with the following items of information.

1. Chip Resistor
2. Part Number
3. Tolerance
4. Quantity
5. Lot # for production month/year/suffix L*
6. Manufacturer's name or symbol

* The suffix "L" indicates that this item is lead free. As of September 2004, all new production items of this are lead free and in compliance with Lead Free/RoHS.