

CRL Series - Low Ohm Surface Mount Chip Resistors

Custom solutions are available.

HOW TO ORDER

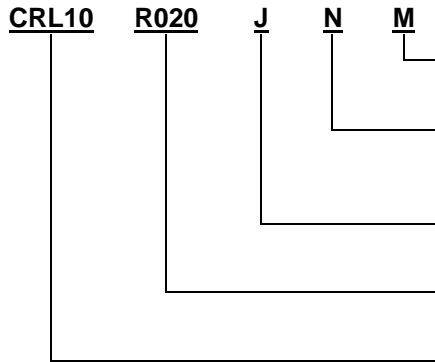

- Packaging**
M = Tape/Reel B = Bulk
- TCR (PPM/°C)**
K=±100 L=±200 N=±300
O=±400 Q=±600 M=±500
- Tolerance (%)**
F = ±1 G = ±2 J = ±5
- EIA Resistance Value**
Standard decade values
- Series Size**
CRL05 = 0402 CRL12 = 2010
CRL16 = 0603 CRL01 = 2512
CRL10 = 0805 CRL01P = 2512
CRL18 = 1206 CRL1S = 3720
CRL14 = 1210 CRL02 = 7520

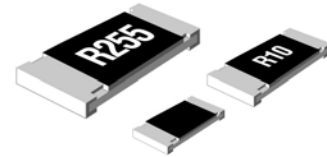

FEATURES

- Resistance Tolerances as low as ±1%
- TCR as low as ± 100ppm
- Wrap Around Terminal for Flow Soldering
- Anti-Leaching Nickel Barrier Terminations
- RoHS Compliant
- Applicable Specifications: EIA575, MIL-R-55342F, and CECC40401

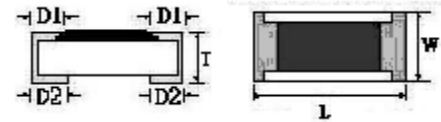

DERATING CURVE

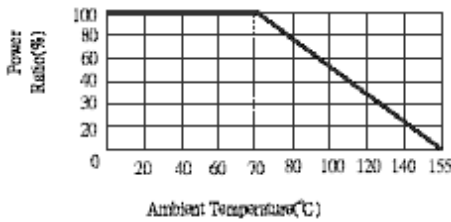

DIMENSIONS (mm)

Size	L	W	D1	D2	Tt
0402	1.00 ± 0.05	0.50 ± 0.05	0.25 ± 0.10	0.20 ± 0.10	0.32 ± 0.05
0603	1.60 ± 0.10	0.80 ± 0.10	0.30 ± 0.20	0.30 ± 0.20	0.45 ± 0.10
0805	2.00 ± 0.15	1.25 ± 0.15	0.30 ± 0.20	0.30 ± 0.20	0.50 ± 0.10
1206	3.10 ± 0.15	1.55 ± 0.15	0.50 ± 0.30	0.40 ± 0.20	0.60 ± 0.10
2010	5.00 ± 0.15	2.50 ± 0.15	0.60 ± 0.30	0.50 ± 0.25	0.60 ± 0.10
2512	6.30 ± 0.15	3.10 ± 0.15	0.60 ± 0.30	0.50 ± 0.25	0.60 ± 0.10
2512-P	6.30 ± 0.20	3.20 ± 0.20	0.70 ± 0.30	2.20 ± 0.20	0.60 ± 0.10
3720	3.75 ± 0.20	2.00 ± 0.20	0.40 ± 0.20	0.40 ± 0.20	0.60 ± 0.10
7520	7.50 ± 0.20	2.00 ± 0.20	0.40 ± 0.20	0.40 ± 0.20	0.60 ± 0.10

ELECTRICAL CHARACTERISTICS

Size	Tolerance (%)	Max TCR (ppm/°C) Per Resistance Range in Ω					Rated Power	Operating Voltage V = √(P*R)	Operating Current I = √(P/R)	Operating Temp. Range is -55°C ~ +150°C
		±600	±400	±300	±200	±175				
0402	±1, ±2, ±5		0.021 ~ 0.049		0.050 ~ 0.910		1/16 W			
0603	±1, ±2, ±5	0.020 ~ 0.050	0.021 ~ 0.049		0.050 ~ 0.910		1/8 W			
0805	±1, ±2, ±5	0.020 ~ 0.100	0.021 ~ 0.049		0.050 ~ 0.910		1/4 W			
1206	±1, ±2, ±5	0.020 ~ 0.100	0.021 ~ 0.049		0.01	0.02 ~ 0.01	1/2 W			
1210	±1, ±2, ±5	0.02 ~ 0.300	0.021 ~ 0.049	±500	0.01		1/4 W			
2010	±1, ±2, ±5		0.021 ~ 0.049		0.050 ~ 0.910		3/4 W			
2512	±1, ±2, ±5		0.021 ~ 0.049		0.050 ~ 0.910		1 W			
2512-P	±1, ±2, ±5		0.021 ~ 0.049			0.02 ~ 0.01	2W			
3720	±1, ±2, ±5			0.010 ~ 0.050			1 W			
7520	±1, ±2, ±5			0.001 ~ 0.010			2 W			

PERFORMANCE

Item	Specification	Test Method
Temp. Coefficient of Resistance	As Spec	MIL-STD-202F, Method 304 304 +25/-55/+25/+125/+25 °C
Short Time Overload	±(0.5% + 0.05Ω)	JIS-C-5202-5.5 RCWV*2.5orMax Overloading Voltage 5 seconds
Dielectric Withstand Voltage	By type	MIL-STD-202F, Method 301 Apply Max Overload Voltage for 1 minute
Insulation Resistance	>1000M Ω	MIL-STD-202F, Method 302 Apply 100VDC for 1 minute
Thermal Shock	±(0.5% + 0.05Ω)	MIL-STD-202F, Method 107G -55°C ~ +150°C, 100 cycles
Load Life	±(1% + 0.05Ω)	MIL-STD-202F, Method 108A RCWV 70°C, 1.5 hrs ON, 0.5 hrs off, 1000 ~ 1048 hrs
Humidity (Stable State)	±(1% + 0.05Ω)	MIL-STD-202F, Method 103B 40°C, 90-95%RH, RCWV 1.5 hrs ON, 0.5 hrs OFF, total 1000 ~ 1048 hrs
Resistance to Dry Heat	±(0.5% + 0.05Ω)	JIS-C-5202 7.2 96 hours @ +125°C without load
Low Temperature Operation	±(0.5% + 0.05Ω)	JIS-C-5202 7.1 1 hour, -65°C followed by 45 minutes if RCWV
Bending Strength	±(0.5% + 0.05Ω)	JIS-C-5202 6.1.4 Bending Amplitude 3mm for 10 seconds
Solderability	95% min. Coverage	MIL-STD-202F, Method 208H 235°C±5°C, 2±0.5 (sec)
Resistance to Soldering Heat	±(0.5% + 0.05Ω)	MIL-STD-202F, Method 210E 260±5°C, 10±1second